

POISON SPYDER

C U S T O M S

YJ TRAIL CAGE KIT INSTALL

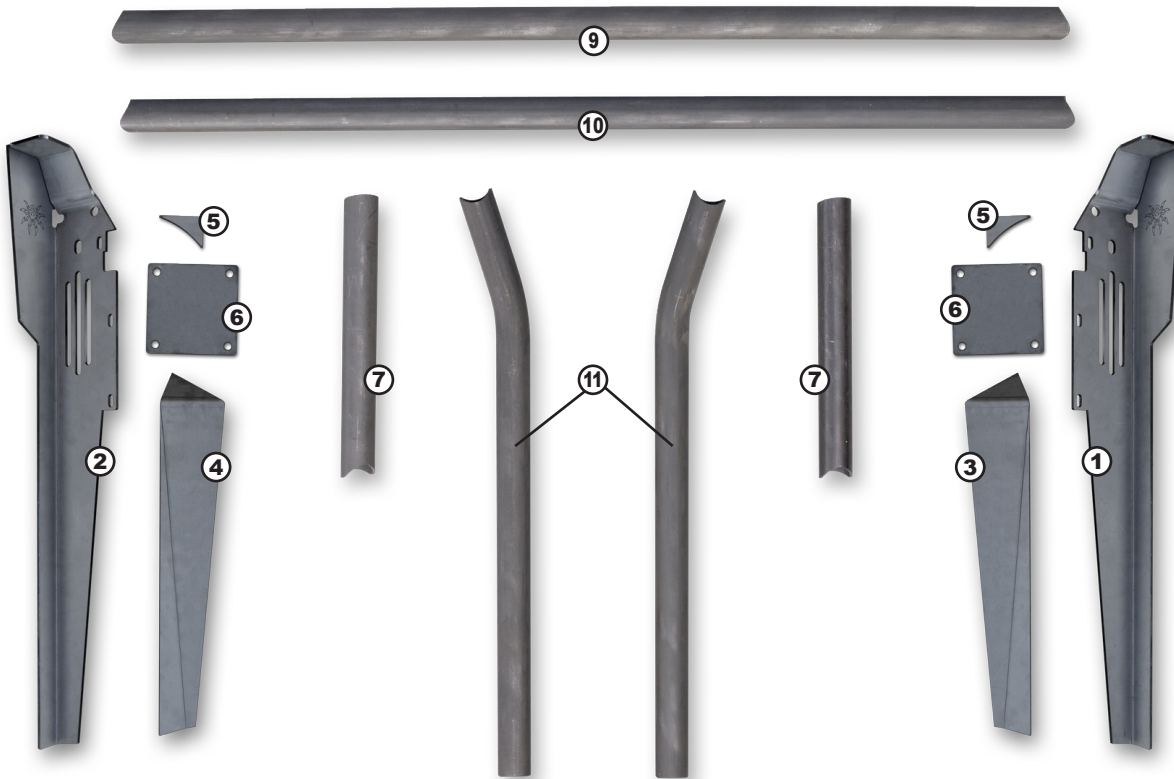

Thank you for purchasing a Poison Spyder Full Cage Kit for your Jeep TJ. Poison Spyder's innovative Lazer-Fit technology provides for the easiest, fastest installation of any aftermarket full cage kit on the market. Installation does require specialized skills and tools, such as welding. If you are not confident in your mechanical skills, please seek the help of a professional to perform the installation. Please read through these entire instructions before proceeding with installation.

PARTS LIST

Please check your packages immediately upon arrival to ensure that everything listed is included, and to check for damage during shipping. If anything is missing or damaged, call Poison Spyder at (951) 849-5911 as soon as possible.

- (1) YJ Lower A-Pillar Left ①
- (1) YJ Lower A-Pillar Right ②
- (1) YJ Lower A-Pillar Inner Plate Left ③
- (1) YJ Lower A-Pillar Inner Plate Right ④
- (2) A-Pillar Top Gusset ⑤

- (2) A-Pillar Foot Plate ⑥
- (2) Upper A-Pillar Tube L&R ⑦
- (1) Dash Bar ⑨
- (1) A-Crossbar ⑩
- (2) Forward Stringer L&R ⑪

TOOLS NEEDED

- Mechanic's tool set including Torx bits
- Welder and proper welding equipment
- Protective welding blankets
- Square and measuring tape

INSTALLATION NOTES

HARDWARE is not provided. You will need to source eight (8) each 3/8" bolts, washers and nuts for bolting the A-Pillar foot plates to the Jeep's floorboard. We recommend using Grade 8 hardware.

Installation of the Trail Cage Kit can take up to 4 hours. This kit requires welding, which should

be done by a certified welder. You will need a friend or two to assist with the installation.

IMPORTANT: It is imperative that the top, doors, seats, plus any other components that are going to be reinstalled after the cage install be test-fitted BEFORE final welding of the cage! Poison Spyder Customs is not liable for fitment issues due to negligent install.

NOTE: Carefully inspect each part and its placement prior to tacking and finish-welding. Each step should be extrapolated for both sides, where any procedure is to be duplicated on both sides of the cage.

INSTALL PROCEDURE

1. **Clean ALL bare metal** pieces provided in the kit, using a clean rag and brake cleaner. This will ensure an easier, cleaner installation and better welds later in the installation.
2. **Weld the Inner Plate** to the inside of each Lower A-Pillar. Align the bottom and two long side edges of the Inner Plate and the Lower A-Pillar. It is not necessary to put a continuous bead all the way around the Inner Plate. Stitch-welding in 1" increments will yield plenty of strength. If a full weld is desired for aesthetics, stitch-weld in increments to keep the assembly from warping during welding. The result will be a fully boxed bottom section of the Lower A-Pillar.
3. **Weld the Top Gusset** onto each Lower a-Pillar. It will fit into the only open 90° bend at the top end of the A-Pillar.
4. **Park vehicle on a level surface** and set the emergency brake. Remove existing cage components, plastic covers, or any other equipment that will be in the way. Use welding blankets to protect the dash and interior of the Jeep from weld splatter.
5. **Along either side of the Jeep's dash** there are four bolts going into the firewall, which match the slotted bolt pattern found on the A-Pillars. Remove these bolts from both sides.
6. **Install the Lower A-Pillars** into place using the three bolts you removed during in the previous step. The mounting holes in the A-Pillars are slotted to allow for vertical adjustment. Leave the bolts only snug enough to hold the A-Pillars in place but loose enough to allow them to slide up and down within the slots.
7. **Position the Foot Plates** beneath each A-Pillar. Make sure the plates are positioned so that the A-Pillar lands as close to the center as possible, but so the bolt holes that must be drilled through the floor are correctly located away from any obstructions underneath the floor. Tack-weld the A-Pillars to the Foot Plates.
8. **Drill the four bolt holes** into the Jeep's floorboards, using the holes in each of the Foot Plates as your drill guide. Bolt the Foot Plates into place (hardware not included in Kit).
9. **Grind or sand the paint** from the locations on the factor roll cage where the pieces of the Trail Cage will be welded in. This includes the forward edge of the main hoop, at the center where the Forward Stringers attach. It also includes the underside of each windshield support bar near the windshield, where the Upper A-Pillar Tubes will attach.
10. **Install the A-Crossbar** ⑩ and the Forward Stringers L&R ⑪ at the same time. Have a friend help with holding the three pieces in place. Start by holding the A-Crossbar in place between the two windshield support bars (or Poison Spyder Header Bars, if used), toward the front of the Jeep.



FIGURE 4

Next, hold the two Forward Stringers in place between the A-Crossbar and the main hoop of the factory cage. Use the laser-etched marks to properly locate the tube junctions along the A-Crossbar. Use a square to ensure that the Forward Stringers

are perpendicular to the main hoop of the factory cage. Use the Forward Stringers to locate the A-Crossbar the proper distance forward from the main hoop of the factory roll cage. Use a measuring tape to confirm that the A-Crossbar is the same distance from the windshield at each end. While holding everything in place correctly located, tack the A-Crossbar and Forward Stringers into place.



FIGURE 4

11. Install the Upper A-Pillar Tubes L&R ⑦ and the Dash Bar ⑨ at the same time. Have a friend help with holding the three pieces in place. Start by holding the Upper A-Pillar Tubes in place between the Lower A-Pillar and the OE windshield support bar or PSC Header Bar. Next, hold the two Dash Bar in place horizontally between the C-Hoop and the lower ends of the Main Side Upper A-Pillar Tubes. Use the laser-etched assembly marks as guides to properly locate the tube junctions. While holding them in place correctly located, tack the Upper A-Pillar Tubes and Dash Bar into place.



FIGURE 5

12. Fully test-fit all equipment that is located within, near or around the cage or any

portion of the cage. This includes soft tops, doors, seats, etc. Test each component for both fit and operation. It is **EXTREMELY IMPORTANT** that you verify proper fitment of all components at this time. If any tube placement needs to be adjusted, it is a simple matter of grinding the small tack welds to make any adjustments. Making these adjustments will be impossible once the cage is fully welded.

13. Finish-weld each joint in the cage. Before you begin, you may wish to place welding blankets or some other suitable protection for your Jeep's interior. You will need to tilt the windshield forward to fully access each seam that must be welded.

14. Paint or powder-coat your cage to protect it from rust. If painting it yourself, use a good quality self-etching primer on the bare steel of your cage prior to painting in the color of your choice. It is recommended to remove the entire cage for painting in order to cover the hard-to-reach parts of the cage.

Congratulations, you have completed the installation of your Poison Spyder Trail Cage Kit!

WARRANTY

Poison Spyder Customs™ warranties all of the products we sell and distribute for one (1) year from the date of sale. These products will be free from defects in material and workmanship under normal installation, and use. Due to the intended use the powder coat finish is warranted for ninety (90) days. The finish warranty will not cover a product if it has been damaged in any way. Warranty is limited to repair or replacement. Poison Spyder Customs™ does not offer any type of labor or shipping allowance and all warranty claims are subject to inspection by Poison Spyder Customs™.

At the discretion of Poison Spyder Customs™, the products in question can be repaired or replaced when found defective. Prior to any replacement or repair, written authorization must be obtained from Poison Spyder Customs™. Failure to contact us prior to having warranty work preformed will immediately void all applicable warranties; and it is then the sole responsibility of the customer to remit any payment incurred.

The warranty expressed above is the sole warranty of Poison Spyder Customs™, and any other expressed or implied warranties are hereby specifically excluded and disclaimed.

HOLD HARMLESS AGREEMENT

1. In purchasing a Poison Spyder Customs Product™ I release, waive, discharge and covenant not to sue Poison Spyder Customs officers, servants, agents, or employees (hereinafter referred to as Releasees) from any and all liability, claims, demands, actions and causes of action whatsoever arising out of or related to any loss, damage, or injury, including death, that may be sustained by me (or anyone else), any property belonging to me (or anyone else), whether caused by the negligence of the releasees or otherwise, while working on, using or any activity related to this product.
2. I am fully aware of risks and hazards connected with the use of a this product and I elect to voluntarily engage in such use of this product knowing that the use may be hazardous to me and my property. I voluntarily assume full responsibility for any risks of loss, property damage or personal injury, including death,

that may be sustained by me (or anyone else), or any loss or damage to property owned by me (or anyone else), as a result of using this product, whether caused by the negligence of releasees or otherwise.

3. I further agree to indemnify and hold harmless the releasees from any loss, liability, damage or costs, including court cost and attorney fees, that they may incur due to my use of a this product, whether caused by negligence of releasees or otherwise.
4. It is my express intent that this Release and Hold Harmless Agreement shall bind the members of my family and spouse, if I am alive, and my heirs assigns and personal representative, if I am deceased, and shall be deemed as a release, waiver, discharge, and covenant not to sue the above named releasees. I further agree that this Waiver of Liability and Hold Harmless Agreement shall be construed in accordance with the laws of the State of California.

By accepting this product, I acknowledge and represent that I have read the above Waiver and Liability and Hold Harmless Agreement, understand it and accept it voluntarily as my own free act and deed; no oral presentations, statements, or inducements, apart from the foregoing written agreement, have been made; I am at least eighteen (18) years of age and fully competent; and I execute this Release for full, adequate and complete consideration fully intending to be bound by same.

If you do not agree with the preceding Hold Harmless Agreement, you may return the product and receive a full refund. Please, contact a Poison Spyder Customs™ sales representative and they will issue a call tag for the product in question. Once the product has been received by Poison Spyder Customs™ a full refund will be issued.

INSTALLATION INSTRUCTIONS