



Jeep JL Rear Track Bar Bracket for 4" Lift

Instructions

www.teraflex.com

Kit #1953600 Jeep JL Wrangler, Rear Track Bar Bracket 4" Lift

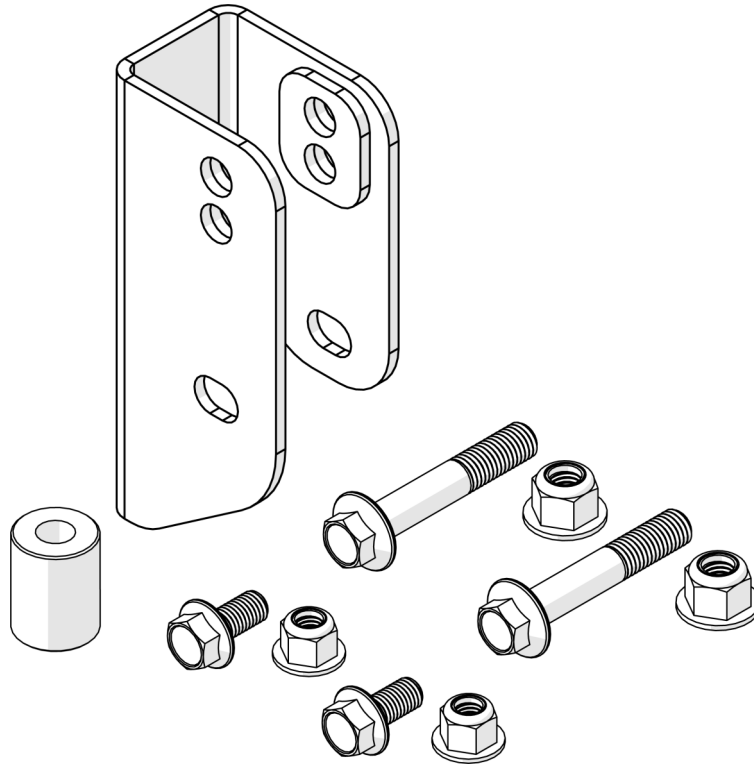

Important Notes:

This bracket requires at least a 2" bump stop spacer to prevent damage to the body during suspension cycle.

Prior to beginning this install, or any installation, read the instructions thoroughly to familiarize yourself with the required steps. Evaluate if you are experienced and capable to personally perform these modifications. A factory service manual should be used in conjunction with these installation instructions.

This product will change the highway handling characteristics of your vehicle, exercise caution. After altering the suspension it is always advisable to have an alignment done by a competent 4 wheel drive shop or by an alignment shop that is experienced with lifted 4 wheel drive vehicles.

Refer to the parts list to ensure that all necessary components and hardware has been included. If any parts are missing please contact your local TeraFlex dealer for assistance.

Refer to the factory service manual for the torque specs of the originally equipped hardware.

Tools needed:

- Basic Mechanics Tool Set
- Factory Service Manual
- Drill
- 1/2" Drill Bits
- Pilot Drill Bit
- Center Punch
- Torque Ratchet

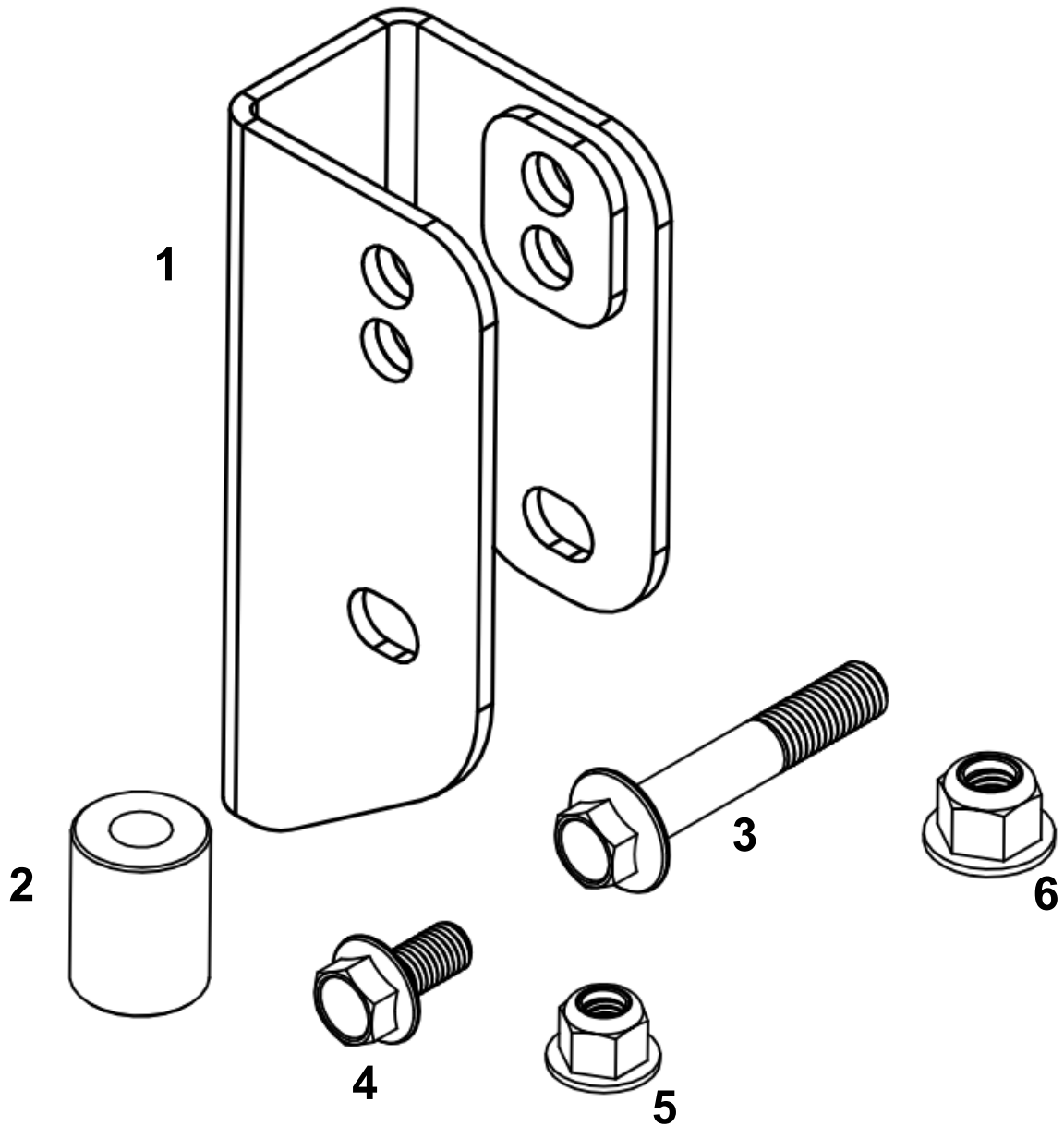

Parts List

Item #	Part Number	Description	QTY
1	15-04-209-003	Bracket, Track Bar, Rear / Jeep JL, 2.5" to 4" Lift / Assembly	1
2	56-13-16-056-2-1	Spacer, 1.25" OD, 1.625" Length, .5625" ID, Aluminum 6061-T6	1
3	45-02-003-011	Hex Flange Bolt, Alloy Steel / Yellow Zinc, M14 x 2.0 x 80mm	2
4	45-02-003-013	Hex Flange Bolt, Alloy Steel / Yellow Zinc, M12 x 1.75 x 25mm	2
5	45-08-003-001	Flange Top Lock Nut, Alloy Steel / Yellow Zinc, M12 X 1.75	2
6	45-08-003-003	Flange Top Lock Nut, Alloy Steel/Yellow Zinc, M14 x 2.0	2

NOTE: This bracket can be installed with the Jeep on the ground and with the wheels installed. If installed with the Jeep lifted do not torque track bar bolts until Jeep is back on the ground and at ride height.

Loosen the frame side track bar bolt, do not remove bolt. Remove the axle side track bar bolt. [21mm]

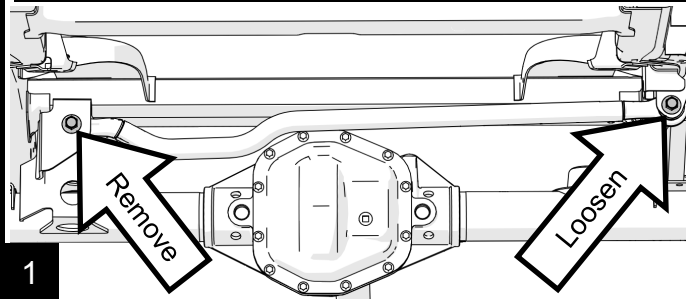

1

Place the track bar on top of the track bar mount. Temporarily install track bar relocation bracket onto the factory track bar mount with provided M14 bolt and nut.

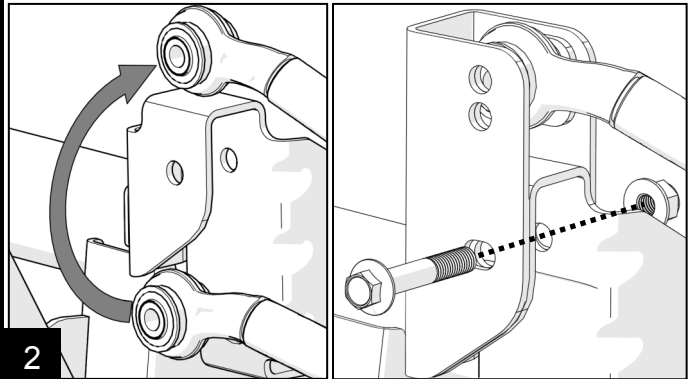

2

Mark the location for both holes to be drilled. Remove the bracket and drill a 1/2" hole in both locations.
TIP: For the best results use a center punch and drill a pilot hole.

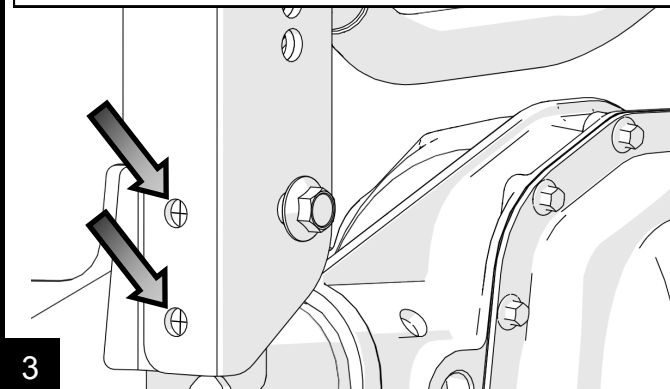

3

Install track bar bracket with the provided M12 bolt and M12 nut into the holes just drilled. Do not tighten bolts.

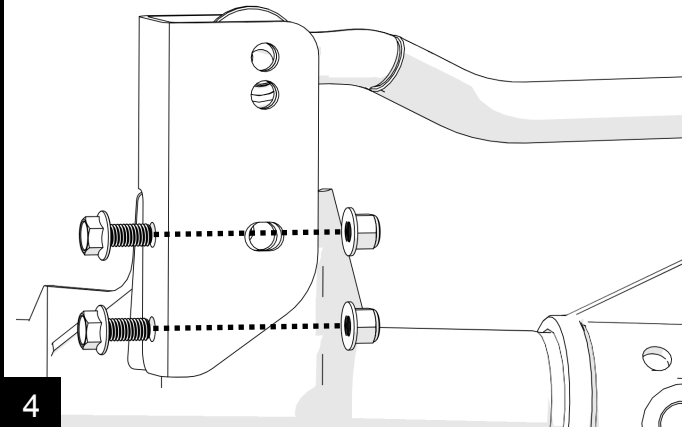

4

Install provided M14 bolt, spacer, and M14 nut into track bar relocation bracket and mount.
Torque provided M12 bolts to 95 ft-lbs. [16mm & 18mm]
Torque provided M14 bolt to 150 ft-lbs. [18mm & 21mm]

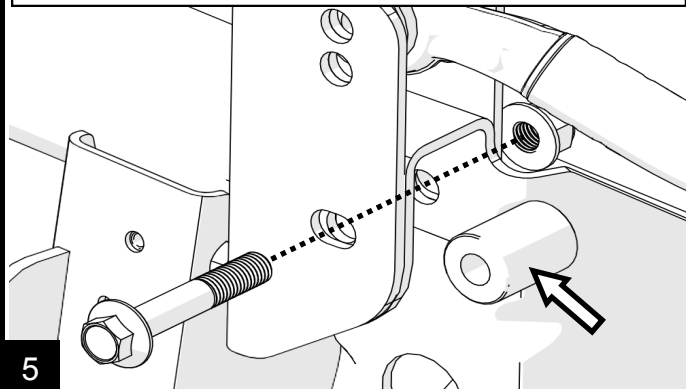

5

Install track bar onto relocation bracket using provided M14 bolt and nut. The lower position is for 2.5 - 3" lifts and upper position is for 4" lifts. Torque provided M14 bolt to 150 ft-lbs. [18mm & 21mm] Torque frame side track bar bolt to factory recommended specs. [21mm]

Install is now Complete

Maintenance Note: After the first 100 miles and every 3,000 miles after that, re-torque all the suspension components and bolts.

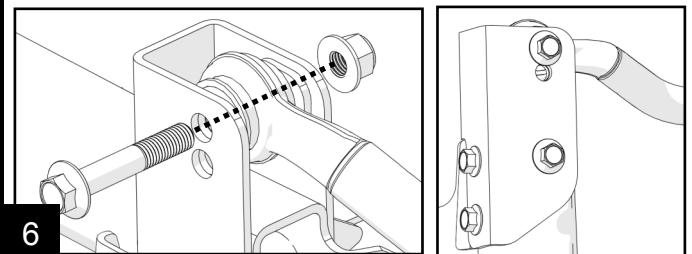

6

PRODUCT INFORMATION

MAINTENANCE INFORMATION:

It is the buyer's responsibility to have all suspension, drivetrain, steering, and other components checked for proper tightness and torque after the first 100 miles and every 3000 miles after that.

NOTICE TO INSTALLER:

The enclosed "Warning to Driver" sticker must be installed in the vehicle in driver's view. This sticker is to act as a constant safety reminder when operating the vehicle. It is your responsibility as the equipment installer to install the provided sticker and to forward the product instructions to the vehicle's owner for review. If a "Warning to Driver" sticker or product installation guide were not included in the kit, FREE replacement stickers and instructions are available by request. It is the installer's duty to ensure a safe and controllable vehicle after the modifications have been performed.

WARNING:

Neither the seller nor the manufacturer will be liable for any loss, damage, or injury directly or indirectly arising from the use of or inability to determine the use of these products. Before using, the user shall determine the suitability of the products for its intended use, and the user shall assume all responsibility and risk in connection therewith.

WARNING TO DRIVER:

This vehicle has been modified to enhance off road performance and has unique handling characteristics. Use in harsh environments can cause extreme stress on the components. Vehicle should be inspected after being off road to make sure that all the components are in working order and safe to travel on the highway. All fasteners should be checked so that they are at the correct torque specifications as the vibration and stresses from off roading may cause critical fasteners to work loose. Extra care should be taken to inspect the critical components, steering, and brake systems. During each oil change components such as arms, tie rod ends, etc should be greased and checked for excessive wear. Any worn components should be replaced. When returning to the pavement always set or restore tire air pressure to the factory recommendation and connect or engage any disabled sway bar mechanisms. Because of the higher center of gravity and larger tires, this vehicle handles and reacts differently than many passenger cars, both on and off road. You must drive it safely! Extreme care should be taken to prevent vehicle rollover or loss of control, which can result in serious injury or death. Avoid sudden sharp turns or abrupt maneuvers. Generally, braking performance and capabilities are decreased when significantly larger/heavier tires are used, especially when used in combination with transfer case low-range reduction kits. Take this into consideration while driving. Do not add, alter or fabricate any factory or aftermarket parts to increase vehicle height over the intended height of the TeraFlex product purchased. Mixing component brand is not recommended. TeraFlex Inc. will not be responsible for any altered product or any improper installation or use of our products. We will be happy to answer any questions concerning the design, function, and correct use of our products. It is ultimately the buyer's responsibility to have all bolts/nuts checked for tightness after the first 100 miles and then every 3000 miles. Wheel alignment, steering system, suspension and drive line systems must be inspected by a qualified professional mechanic at least every 3000 miles.

TERAFLEX PRODUCT WARRANTY:

TeraFlex Inc. warrants TeraFlex Suspension products to the original retail purchaser to be free of defects in material and workmanship for as long as the original purchaser owns the vehicle on which products were originally installed.

Failure to complete regular maintenance (grease every 3000 miles) on TeraFlex FlexArms will void this warranty. All other conditions of the standard TeraFlex product warranty apply.

All TeraLow products are covered by the TeraFlex two (2) year warranty to be free of defects in material and workmanship for two years from date purchased.

TeraFlex axles are covered by a 12-month warranty to be free of defects in materials and workmanship.

This warranty does not cover or include product finish, improperly installed or applied products, improperly maintained products, products or components used for racing or competition or damage due to abuse or neglect, products that fail due to the use of larger tire and wheel combinations.

All returns must be accompanied by an original invoice. It is the customer's responsibility to remove the product from the vehicle. Shipping charges are the responsibility of the customer. TeraFlex Inc. will pay the return freight if the product meets the terms of warranty.

This warranty is for the replacement or repair of defective TeraFlex products only and does not include freight charges, labor charges for removal of or installation of TeraFlex or related products or components, costs incurred due to down time of the vehicle, or lost profits due to vehicle down time.

A returned goods authorization number (RGA#) must accompany any returned products. For more information please contact a TeraFlex customer service representative.

COPYRIGHT

©Copyright 2014. All rights reserved, TeraFlex Inc. Reproduction of this catalog and/or any of its contents without written permission is strictly prohibited.

TeraFlex® is a registered trademark of TeraFlex Inc. All trade names and logos including but not limited to TeraFlex, FlexArms, RockGuard, Monster, and LCG are protected by law and duplication of trade names and/or logos are strictly prohibited.

TeraFlex Inc. reserves the right to update, discontinue, redesign, modify finish, part number or component build parts if deemed necessary without written notice.

TeraFlex Inc., and any associated dealers are not responsible for misprints or typographical errors that may have inadvertently been made within this instruction sheet.

Jeep® and the Jeep® grill are registered trademarks of Fiat Chrysler Automobiles N.V., and have no affiliation with TeraFlex Inc.

TERAFLEX, Inc.
5680 West Dannon Way
West Jordan, Utah 84081
Phone/801.713.3314
Fax/801.713.2313
www.teraflex.com