



## Falcon 3.3 Fast Adjust Upgrade Kit

www.teraflex.com

Kit # 00-10-33-400-160 Universal, Modular Cartridge System, Series 3 / Type 3, **ALL 4**, 1.60" Bore

Kit # 00-10-33-100-160 Universal, Modular Cartridge System, Series 3 / Type 3, **Single**, 1.60" Bore

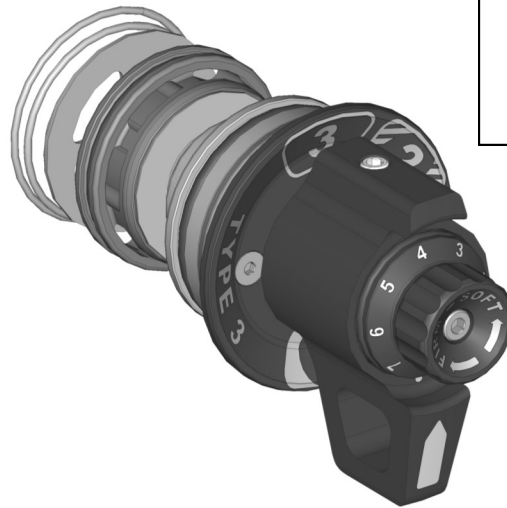

Refer to video online for more information on installing the Falcon 3.3 Modular Cartridge.

### Important Notes:

Prior to beginning this install, or any installation, read through the instructions entirely to familiarize yourself with the required steps and evaluate if you are experienced and/or capable to personally perform these step and modifications. A factory service manual should be used in conjunction with these instructions and installation.

Refer to the parts list to ensure that all necessary components and hardware has been included. If any parts are missing please contact your local TeraFlex dealer for assistance.

**Re-charging your Shocks:** Before starting this install, make sure you have a way to re-charge your shocks to 100 psi. **Incorrect charge pressure can alter shock behavior and could ultimately lead to failure.** Your Falcon Shocks were originally charged with nitrogen from the factory, and it is recommended that they be re-charged with nitrogen if possible. However, compressed air can be used if nitrogen is not readily available.

**Caution:** It is important to keep your shocks clean during disassembly and cartridge installation. To help insure that the install is clean, make sure your work area and shocks are cleaned thoroughly before and through out the entire process. Failure to keep your shocks clean could cause leaks or malfunction.

### Tools needed:

- 3/16", 5mm, 2.5mm, 2mm Allen Sockets or Wrenches
- Pick
- Plyers
- Air Compressor or Air Pump Capable of 100 psi.
- General Mechanics Tools

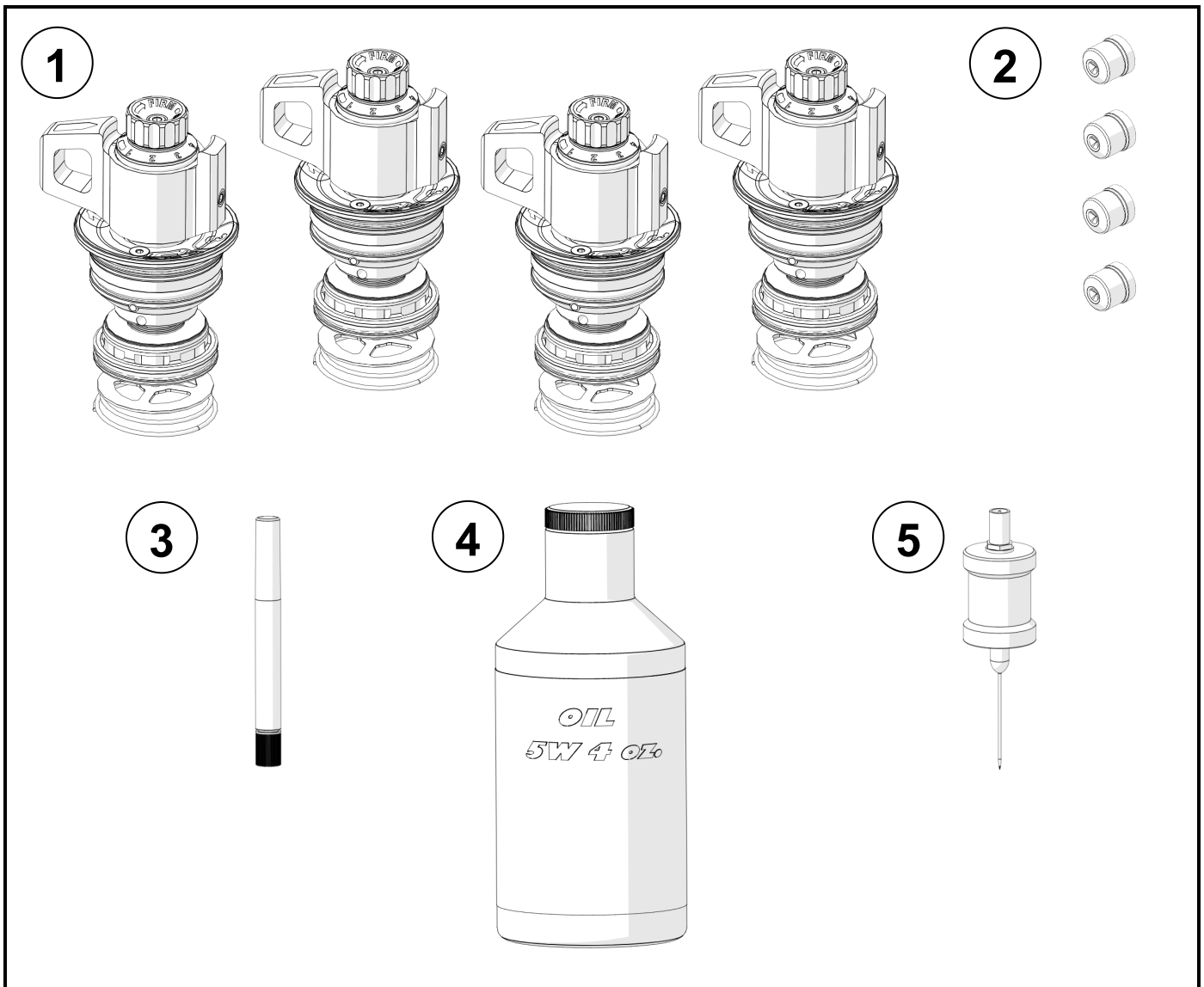

Item #	Part Number	00-10-33-400-160 Full Kit (ALL 4)	Qty
1	00-10-33-100-160	Universal, Modular Cartridge System, Series 3 / Type 3, Single, 1.60" Bore	4
2	15-01-01-001	Seal (S), Plug, Needle Type, 0.250 OD x 0.250 Total Length	4
3	242001	Turbo-Lock Blue Thread Locker	1
4	35-01-01-002	Oil/ Grease (S), Oil, Redline, 4oz Bottled / 5 weight	1
5	50-05-01-008	Tool (S), Nitrogen, Needle Adapter, Schrader Valve / Complete Assembly	1

Item #	Part Number	00-10-33-100-160 Single	Qty
1	00-10-33-100-160	Universal, Modular Cartridge System, Series 3 / Type 3, Single, 1.60" Bore	1

During this install it is best to keep your new parts in the bag until the instructions have you install them. Keeping them in the bag will help you maintain cleanliness.

1

Remove the Falcon Shocks from the vehicle following the steps (in reverse) used to install them.

Clean the Falcon Shocks as well as possible, focusing mostly on the cartridge and the charge port sections of the shocks. A pressure washer and/or soapy water with a scrub brush will be helpful to do this.

2

**Falcon 3.3 Fast Adjust Upgrade Kit Install**

Slowly loosen the charge port set screw.

**Note:** The rubber plug behind the set screw can be blown out of the charge port and get lost. These rubber plugs will be replaced but take care not to lose the set screw. To do this keep the allen wrench in the set screw and apply pressure on it until all the gas leaks out. A rag or towel can be used to cover the port to help catch the set screw.

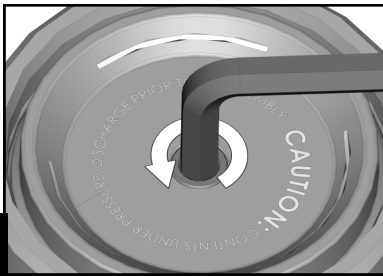

3

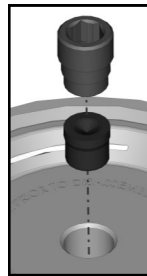

Completely remove the set screw to make sure that the shock is fully discharged.

Lightly oil and install the new rubber plug by pressing it into place with the tip of an allen wrench (small end down). Reinstall the set screw and completely tighten it down, then loosen it back out 1/2 turn.

4

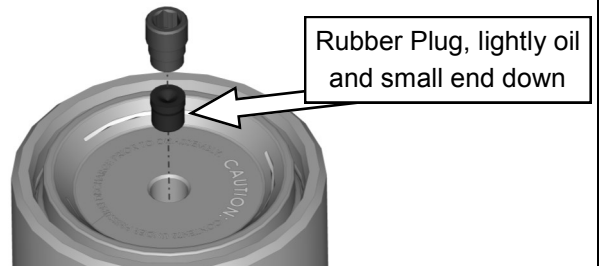

**Note:** Use a soft clap to hold the shock. The cartridge must be flat or oil will spill out. Push down on the top of the cartridge, this will reveal the snap ring. Clean out any dirt that may have been trapped in the snap ring groove.

cartridge must be flat

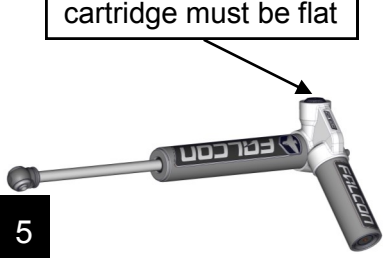

5

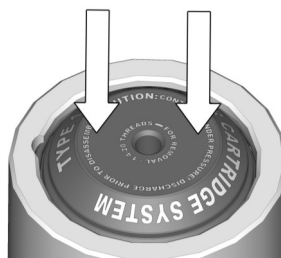

Remove the snap ring. Use a pick and press it behind and under the snap ring where the access notch is. Press the snap ring toward the center and then pry it upward. Follow the snap ring around the cartridge, with your finger, pushing it toward the center and pulling up slightly.

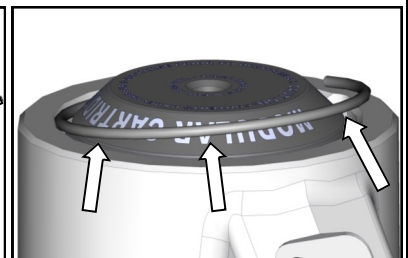
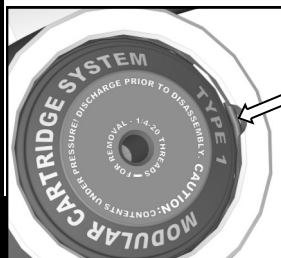

**Note:** The earlier 3.1 cartridge (black) came with a set screw in the center of it that will need to be removed for the next step.

The latest 3.1 cartridge (black) comes with a threaded hole that is all ready for the next step.

And the 3.2 cartridge (gold) have an adjustment pin in the center that is not removable and it has a threaded hole in it that will be used for the next step.

3.1 with set screw      3.1 no set screw      3.2 with adjust pin



7

Thread the correct bolt into the center of the cartridge.

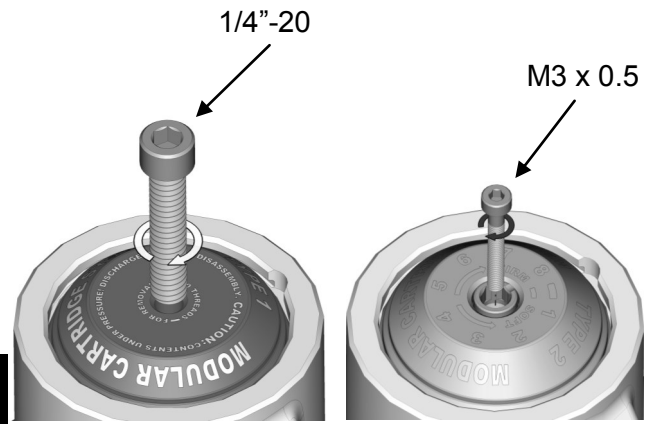

8

Using pliers, pull the cartridge out with a slow and steady pressure. The cartridge has an O-ring that will become lodged in the snap ring groove. When this occurs apply side pressure to the bolt/cartridge in a circular motion while still pulling upward to work the O-ring past the snap ring groove.

**Note:** When the O-ring clears the snap ring groove the cartridge can come out quickly resulting in excessive loss of oil.

Holding your hand over the top of the cartridge can help prevent it from popping out, losing oil, and making a mess.



9

If upgrading from a **3.1** cartridge, install the provided tapered spring.

If upgrading from a **3.2** cartridge ensure that the spring is oriented correctly. The tapered spring is installed with the **larger diameter end first**.

(See image)

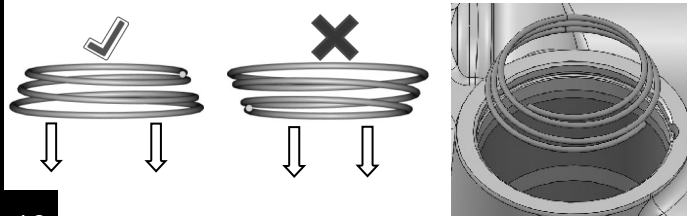

10

Remove the black 8 position knob and bolt with 2.5mm allen. Loosen the red 3 position knob set screw, with a 2.5mm allen, enough to clear the hole in the adjustment pin and remove knob. O-ring surfaces will come pre-greased. Make sure this grease is kept clean and is not removed. This grease ensures proper knob function. Remove the 2 bolts, with a 2mm allen, from the face plate and remove plate.



11

Use the provided oil and fill the cartridge chamber to lower taper line( see image). Excess oil will spill out and over the sides. This is normal and a crucial step for elimination of air pockets in the shock. Place shop towels under and around the shock to help with the mess.



12

The 8 position and 3 position adjustment pins must both be turned all the way counter clockwise for installation. The outer 3 position adjustment pin can be turned by hand. For the inner 8 position adjustment pin use a 5mm allen wrench. Once both pin are clocked slowly lower the 3.3 cartridge into the housing.

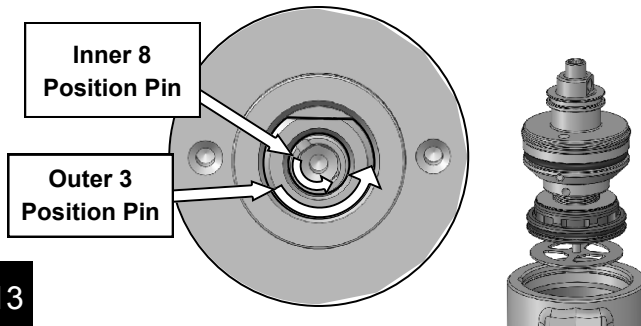

13

Press cartridge down firmly until it stops, exposing the snap ring groove. Install snap ring into the groove, ensuring the end of the snap ring is just past the notch in housing (see image). This will aid in future disassembly if needed.

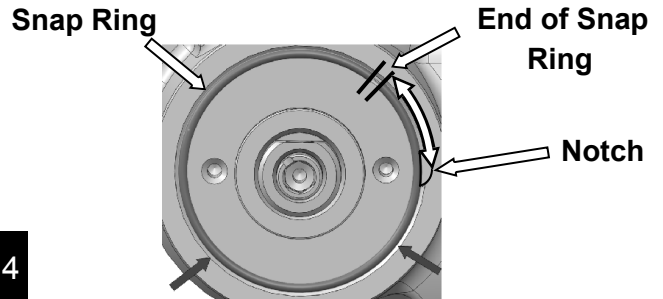

14

Temporarily install the red 3 position knob so the new 3.3 cartridge can be clocked. The set screw needs to go into the hole on the side of the adjustment pin (as seen in illustration).

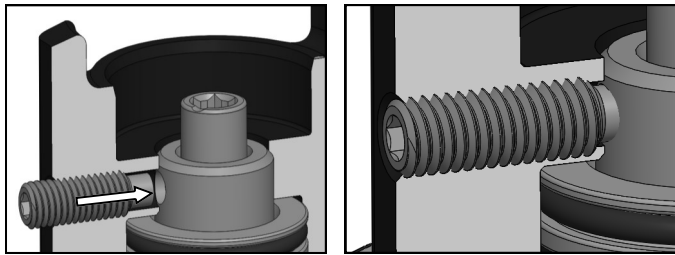

15

The cartridge needs to be clocked so the knob can sweep through a safe path. The front shock knob needs to sweep up and away from the tire. For the rear, the knob needs to sweep up and away from the ground to be protected behind the shock body.

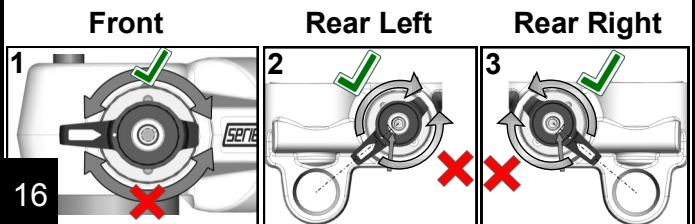

16

Position the trim plate onto the 3.3 cartridge, keeping in mind the sweep of the 3 position knob. Apply a couple of drops of blue thread locker on the threads of the 2 screws and install into cartridge.

**Torque screws to 8 in-lbs.**

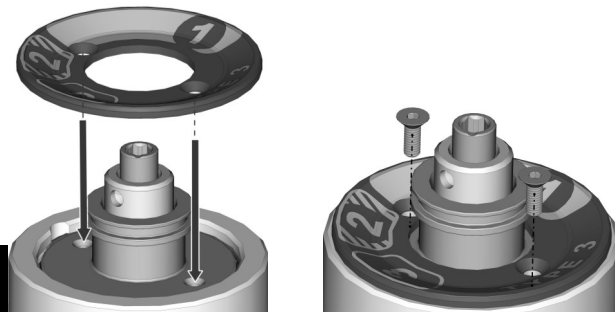

17

Install the red 3 position knob. Install the set screw with a couple of drops of blue thread locker. The set screw needs to go into the hole on the side of the adjustment pin.

**Torque set screw to 8 in-lbs.**

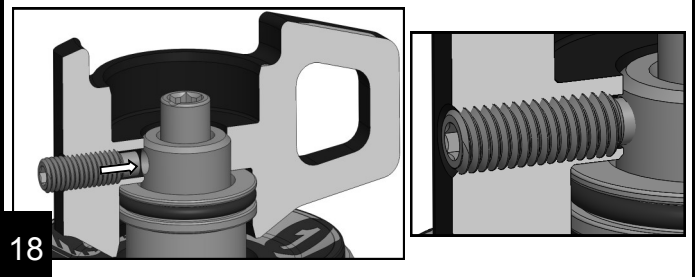

18

With a 5mm allen wrench clock the 8 position adjustment pin by rotating it clock-wise until it stops.

**Note:** Do not force the adjustment pin. Rotation should be smooth and easy and you will be able to feel it when it stops.

19

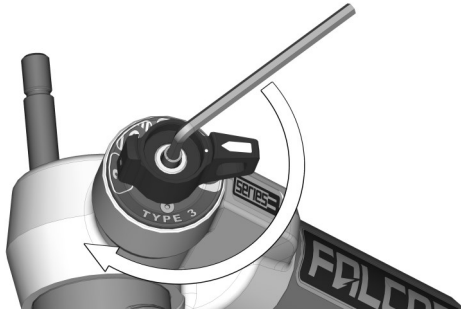

Install the black 8 position knob with the 3mm x 22mm bolt and a couple of drops of blue thread locker (line up the # 8 with the mark on the 3 position knob as shown in illustration). Press down on the black knob firmly and **torque 3mm bolt to 4 in-lbs.**

20

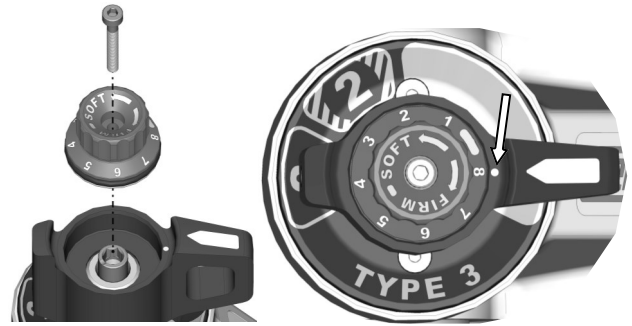

**Note:** Check that the set screw is open 1/2 turn, as explained in step 4.  
Remove the protective cap from the needle and press it into the center of the set screw that was used to discharge the shock. Press the needle all the way in until it stops and is flush with shock. Charge the shock to 100 psi. and remove the needle.

**Torque the set screw to 50 in lbs.**

21

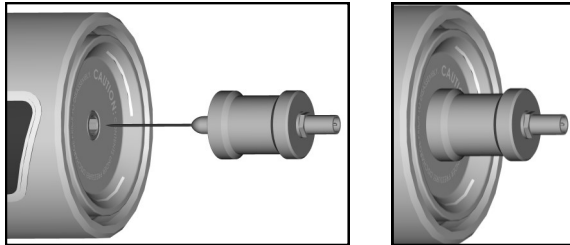

Test the function of the knobs after the shock is charged to make sure they cycle correctly.

Repeat the process on the rest of your shocks.

Reinstall the shocks back onto the vehicle following your Falcon shock installation instructions.

# FALCON

## PRODUCT INFORMATION

### **MAINTENANCE INFORMATION:**

It is the buyer's responsibility to have all suspension, drivetrain, steering, and other components checked for proper tightness and torque after the first 100 miles and every 3000 miles after that.

### **NOTICE TO INSTALLER:**

The enclosed "Warning to Driver" sticker must be installed in the vehicle in driver's view. This sticker is to act as a constant safety reminder when operating the vehicle. It is your responsibility as the equipment installer to install the provided sticker and to forward the product instructions to the vehicle's owner for review. If a "Warning to Driver" sticker or product installation guide were not included in the kit, FREE replacement stickers and instructions are available by request. It is the installer's duty to ensure a safe and controllable vehicle after the modifications have been performed.

### **WARNING:**

Neither the seller nor the manufacturer will be liable for any loss, damage, or injury directly or indirectly arising from the use of or inability to determine the use of these products. Before using, the user shall determine the suitability of the products for its intended use, and the user shall assume all responsibility and risk in connection therewith.

### **WARNING TO DRIVER:**

This vehicle has been modified to enhance off road performance and has unique handling characteristics. Use in harsh environments can cause extreme stress on the components. Vehicle should be inspected after being off road to make sure that all the components are in working order and safe to travel on the highway. All fasteners should be checked so that they are at the correct torque specifications as the vibration and stresses from off roading may cause critical fasteners to work loose. Extra care should be taken to inspect the critical components, steering, and brake systems. During each oil change components such as arms, tie rod ends, etc should be greased and checked for excessive wear. Any worn components should be replaced. When returning to the pavement always set or restore tire air pressure to the factory recommendation and connect or engage any disabled sway bar mechanisms. Because of the higher center of gravity and larger tires, this vehicle handles and reacts differently than many passenger cars, both on and off road. You must drive it safely! Extreme care should be taken to prevent vehicle rollover or loss of control, which can result in serious injury or death. Avoid sudden sharp turns or abrupt maneuvers. Generally, braking performance and capabilities are decreased when significantly larger/heavier tires are used, especially when used in combination with transfer case low-range reduction kits. Take this into consideration while driving. Do not add, alter or fabricate any factory or aftermarket parts to increase vehicle height over the intended height of the TeraFlex product purchased. Mixing component brand is not recommended. TeraFlex Inc. will not be responsible for any altered product or any improper installation or use of our products. We will be happy to answer any questions concerning the design, function, and correct use of our products. It is ultimately the buyer's responsibility to have all bolts/nuts checked for tightness after the first 100 miles and then every 3000 miles. Wheel alignment, steering system, suspension and drive line systems must be inspected by a qualified professional mechanic at least every 3000 miles.

### **TERAFLEX PRODUCT WARRANTY:**

TeraFlex Inc. warrants TeraFlex Suspension products to the original retail purchaser to be free of defects in material and workmanship for as long as the original purchaser owns the vehicle on which products were originally installed.

Failure to complete regular maintenance (grease every 3000 miles) on TeraFlex FlexArms will void this warranty. All other conditions of the standard TeraFlex product warranty apply.

All TeraLow products are covered by the TeraFlex two (2) year warranty to be free of defects in material and workmanship for two years from date purchased.

TeraFlex axles are covered by a 12-month warranty to be free of defects in materials and workmanship.

This warranty does not cover or include product finish, improperly installed or applied products, improperly maintained products, products or components used for racing or competition or damage due to abuse or neglect, products that fail due to the use of larger tire and wheel combinations.

All returns must be accompanied by an original invoice. It is the customer's responsibility to remove the product from the vehicle. Shipping charges are the responsibility of the customer. TeraFlex Inc. will pay the return freight if the product meets the terms of warranty.

This warranty is for the replacement or repair of defective TeraFlex products only and does not include freight charges, labor charges for removal of or installation of TeraFlex or related products or components, costs incurred due to down time of the vehicle, or lost profits due to vehicle down time.

A returned goods authorization number (RGA#) must accompany any returned products. For more information please contact a TeraFlex customer service representative.

### **COPYRIGHT**

©Copyright 2014. All rights reserved, TeraFlex Inc. Reproduction of this catalog and/or any of its contents without written permission is strictly prohibited.

TeraFlex® is a registered trademark of TeraFlex Inc. All trade names and logos including but not limited to TeraFlex, FlexArms, RockGuard, Monster, and LCG are protected by law and duplication of trade names and/or logos are strictly prohibited.

TeraFlex Inc. reserves the right to update, discontinue, redesign, modify finish, part number or component build parts if deemed necessary without written notice.

TeraFlex Inc., and any associated dealers are not responsible for misprints or typographical errors that may have inadvertently been made within this instruction sheet.

Jeep® and the Jeep® grill are registered trademarks of Fiat Chrysler Automobiles N.V., and have no affiliation with TeraFlex Inc.

### **TERAFLEX, Inc.**

5680 West Dannon Way  
West Jordan, Utah 84081  
Phone/801.713.3314  
Fax/801.713.2313  
www.teraflex.com