



SYNERGY MFG. 870 INDUSTRIAL WAY, SAN LUIS OBISPO, CA (805) 242-0397

5019 JK FRONT AIR BUMP KIT (THRU COIL)

GENERAL NOTES:

- These instructions are also available on our website; www.synergymfg.com. Check the website before you begin for any updated instructions and additional photos for your reference.
- This is a weld on kit and should be installed by an experienced welder.
- We recommend installing one side at a time so that the opposing side can be used for reference measurements.
- This kit sets the collapsed bump stop location at the factory metal on metal contact point, therefore all bump stop spacing will be done at the axle side of the suspension.
- This kit is designed to use a 2.0" stroke FOX-983-02-091 air bump. Other air bumps will not be compatible without windshield washer bottle modification or removal.
- Plastic inner fender wells will require trimming after installation of air bumps.
- Disconnect the ground cable from the battery prior to welding as to prevent electrical damage to the vehicle.
- **DISCLAIMER:** Air Bumps make noise. When air bumps engage on their strike pads, there will be an audible clunking sound that will be heard by cabin occupants.

PARTS LIST:

- **5019-01 JK Front Air Bump Kit (Thru Coil)**
 - (2) 501901-01 JK Air Bump Kit, Front Gusset
 - (2) 501901-02 JK Air Bump Kit, Shock Tower Gusset
 - (2) 501902-01 JK Front Air Bump Can

Parts / Tools Needed to complete installation:

- Basic simple hand tools.
- Quality Jack and Jack Stands
- Metal cutting tool. Any of the following will suffice:
 - 4-1/2" Angle Grinder with cut off wheel, or pneumatic powered cut off tool.
 - Sawzall
 - Cutting Torch
 - Plasma cutter
- Welding machine; MIG is preferred, but TIG or stick are acceptable.

APPROXIMATE INSTALL TIME: 3-4 HOURS

INSTALLATION:

- 1) Begin by removing the track bar bolt at the axle side. Bolt # 1 in the image below. Use a 21mm socket / wrench for removal.

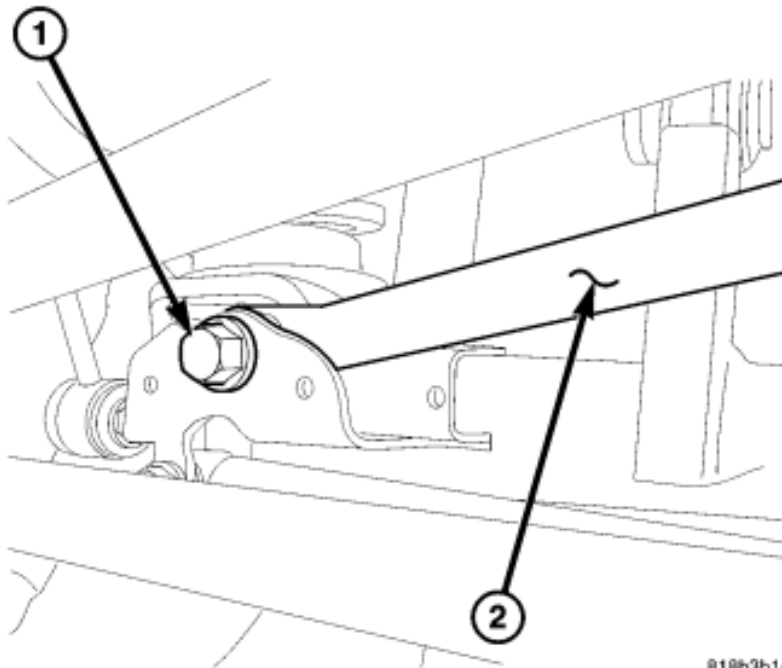

818b3b1d

- 2) Next, jack the vehicle up and support it in a manner that will allow the suspension to hang free. Remove the front tires.
- 3) Remove the plastic inner fender wells.
- 4) Loosen / remove components to the point of coil spring removal. Remove coils and factory bump-stops. Front suspension should be disassembled to the point shown in IMG 4.1 below.



IMG 4.1 Front suspension tear down.

- 5) With upper coil spring isolators removed, remove the front bump stops and take a reference measurement from the underside of the coil tower to the bottom of the jounce tube. This measurement should read 5-3/8"

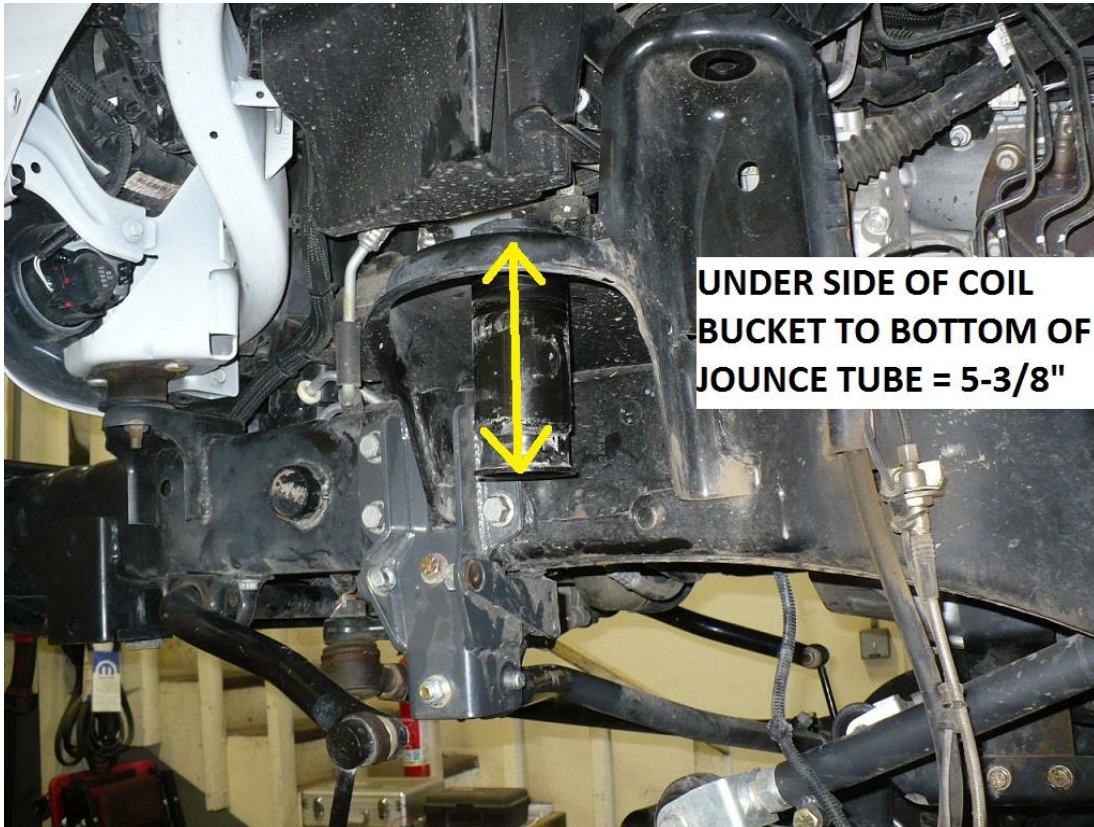

- 6) Next, measure 2.75" from the bottom of the jounce tube and mark a line. This is the cut line. A piece of masking tape will help as a guide to cut a straight line.
- Use a small cutoff wheel or a sawzall and cut off the bottom of the jounce tube.



- 7) Once cut, grind smooth any rough or sharp edges.

- 8) Insert the bump can as pictured below. Note, drivers side will require loosening of windshield washer tray for installation. Steps 9-11 will cover this procedure.
- 9) Remove the 2 bolts securing the windshield washer reservoir tray to the fender rail. Use a 10mm socket. See image below.

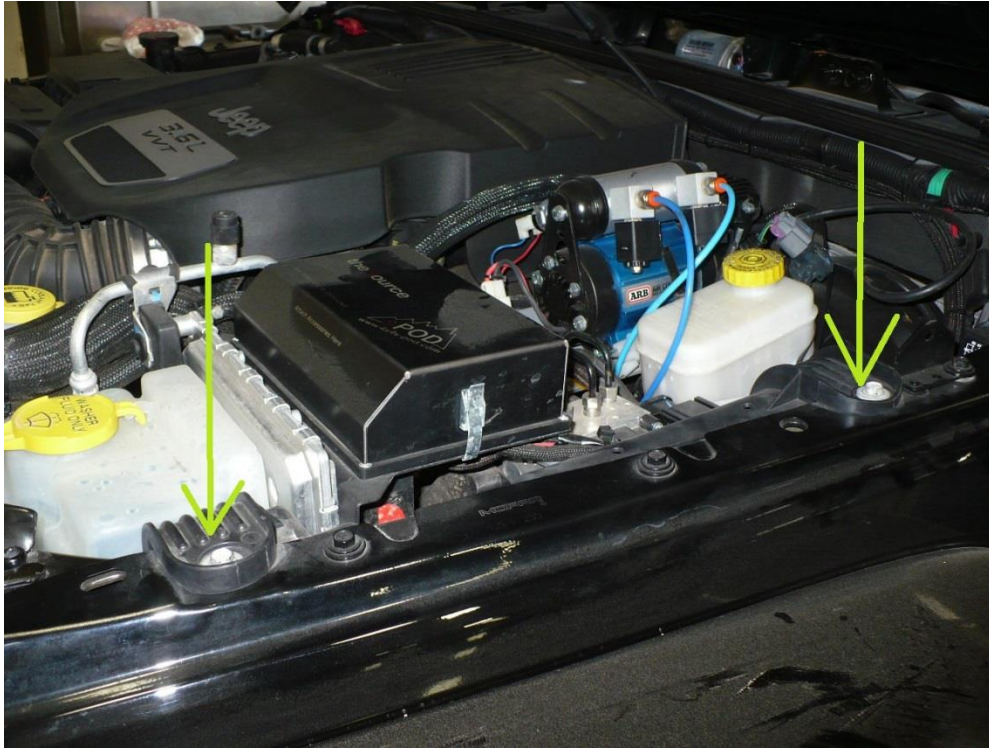

- 10) Remove the lower attachment bolt by the washer reservoir. Use a 10mm socket and a long extension. See image below.



- 11) Lastly, use a 10mm socket and long extension to remove the rear attachment bolt near the front of the brake booster.

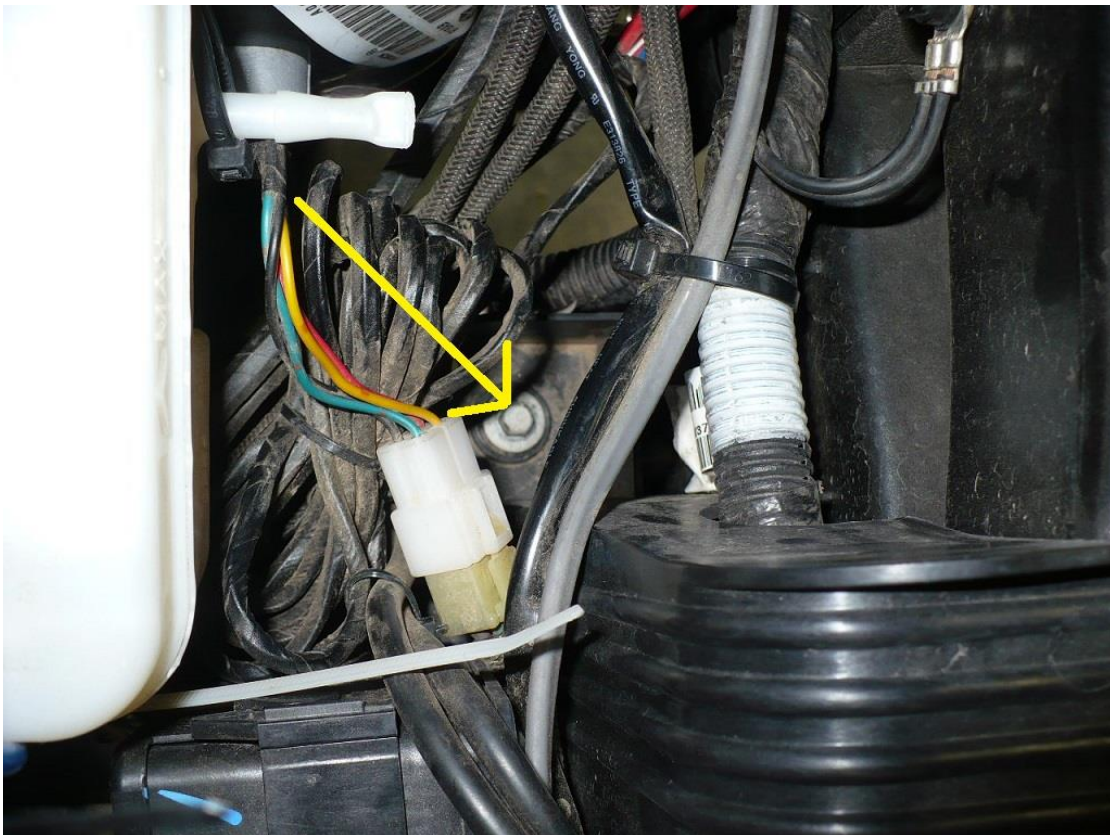
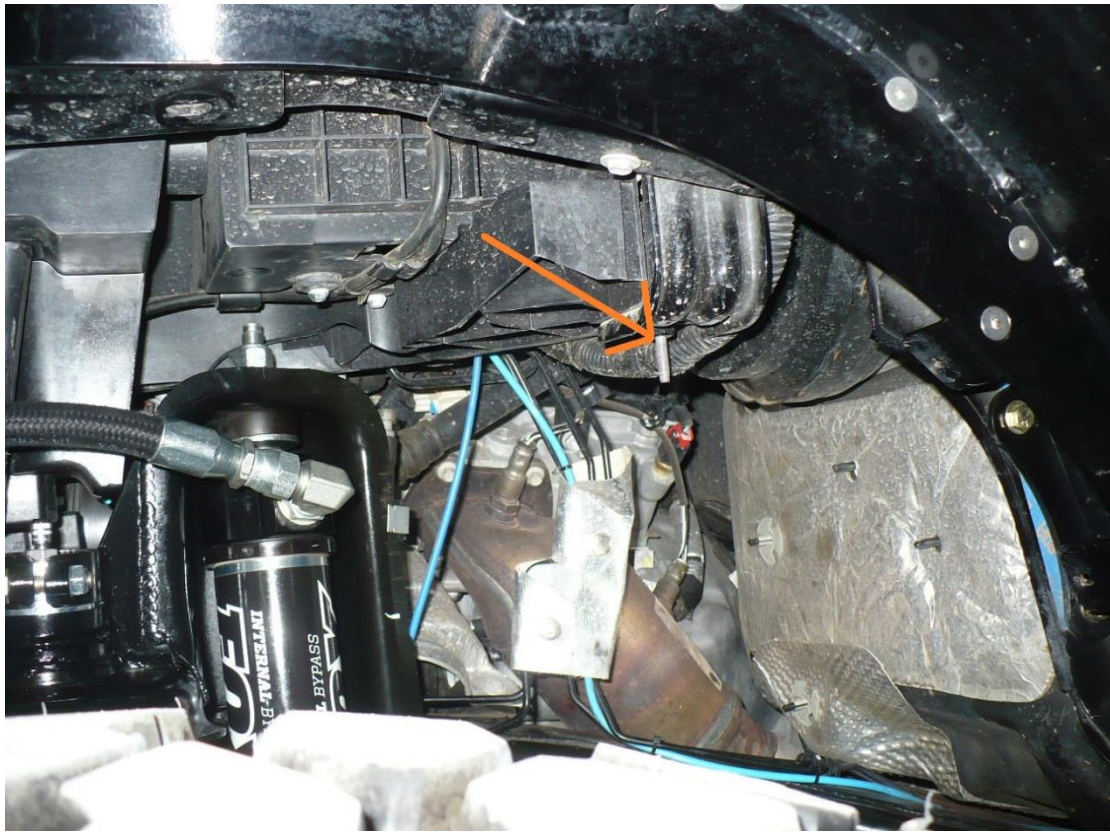

12) With this hardware removed, the washer reservoir tray can be pushed up to allow enough room for the air bump can to be installed. Some gently tapping with a dead blow or rubber mallet may be needed to get the bump can started into the factory jounce tube.



- 13) With bump can in place as pictured below. Take some reference measurements. Note the bump can is machined to a certain point so the height of the can should be approximately correct, however each Jeep is different and some jounce tubes have more material on the top of the coil bucket than others.

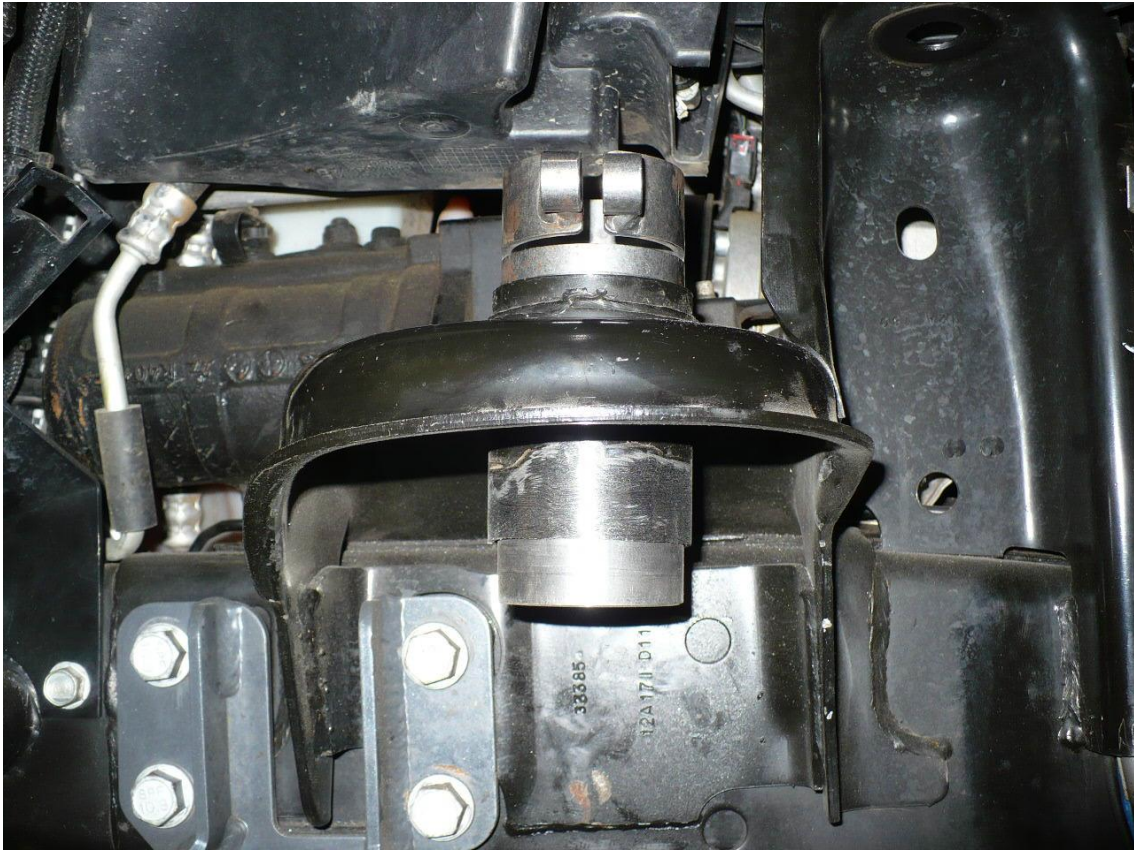

14) The measurement from the top of the coil bucket to the top of the bump can should be about 2-1/4"

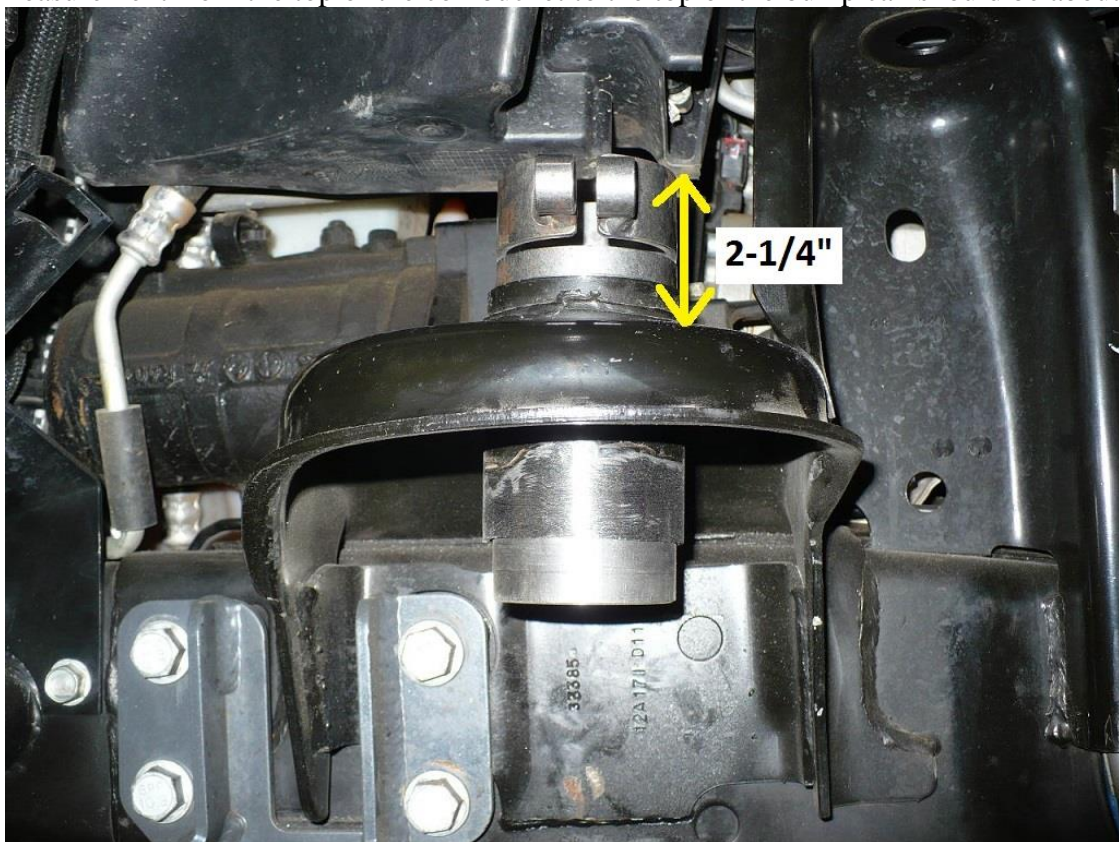

15) Next, take a reference measurement from the underside of the coil bucket to the bottom of the bump can. This should measure 3-3/8". This measurement is critical for accurate bump stop spacing. See picture below for reference measurements.

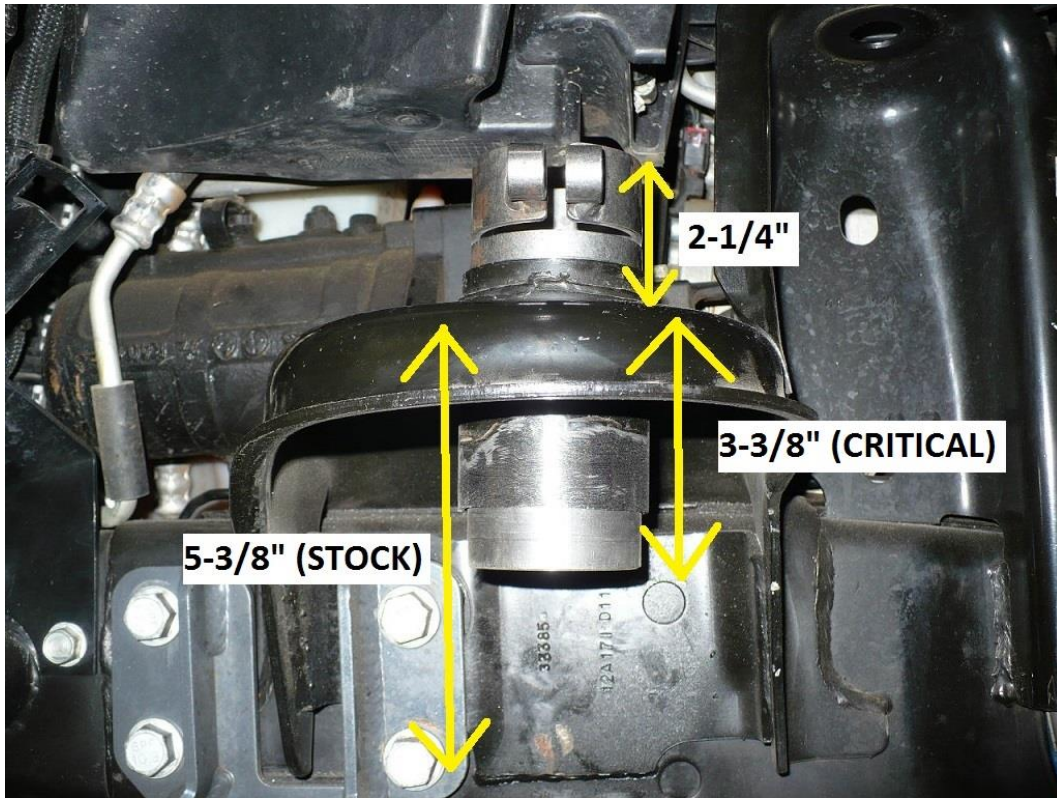

16) Next, test fit both front and rear gussets as shown. Take note of what areas need to be cleaned up for welding.

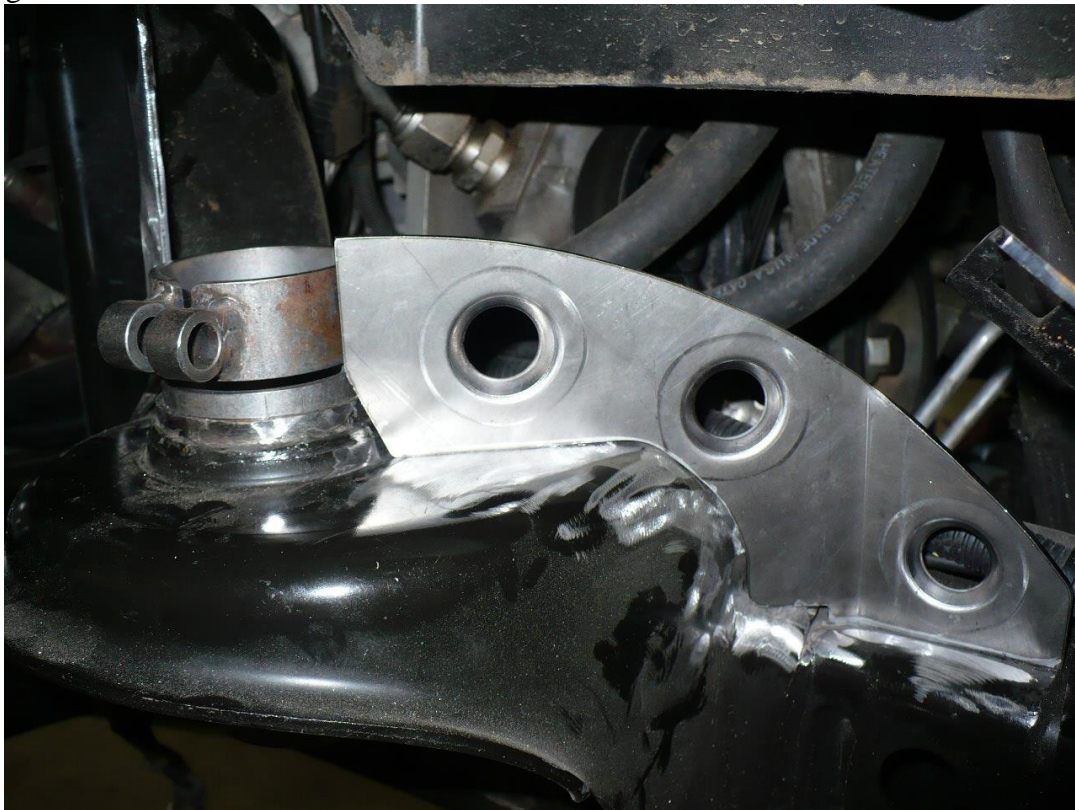



- 17) With areas cleaned up for welding, reposition the bump can and tack weld into place.
- 18) Double check measurements and fully weld in the bump can. Weld as much as possible. The back side of the bump can will be difficult to get a welder to. It is ok to leave the back side un-welded.
- 19) Position gussets and weld in position. Weld as shown below.



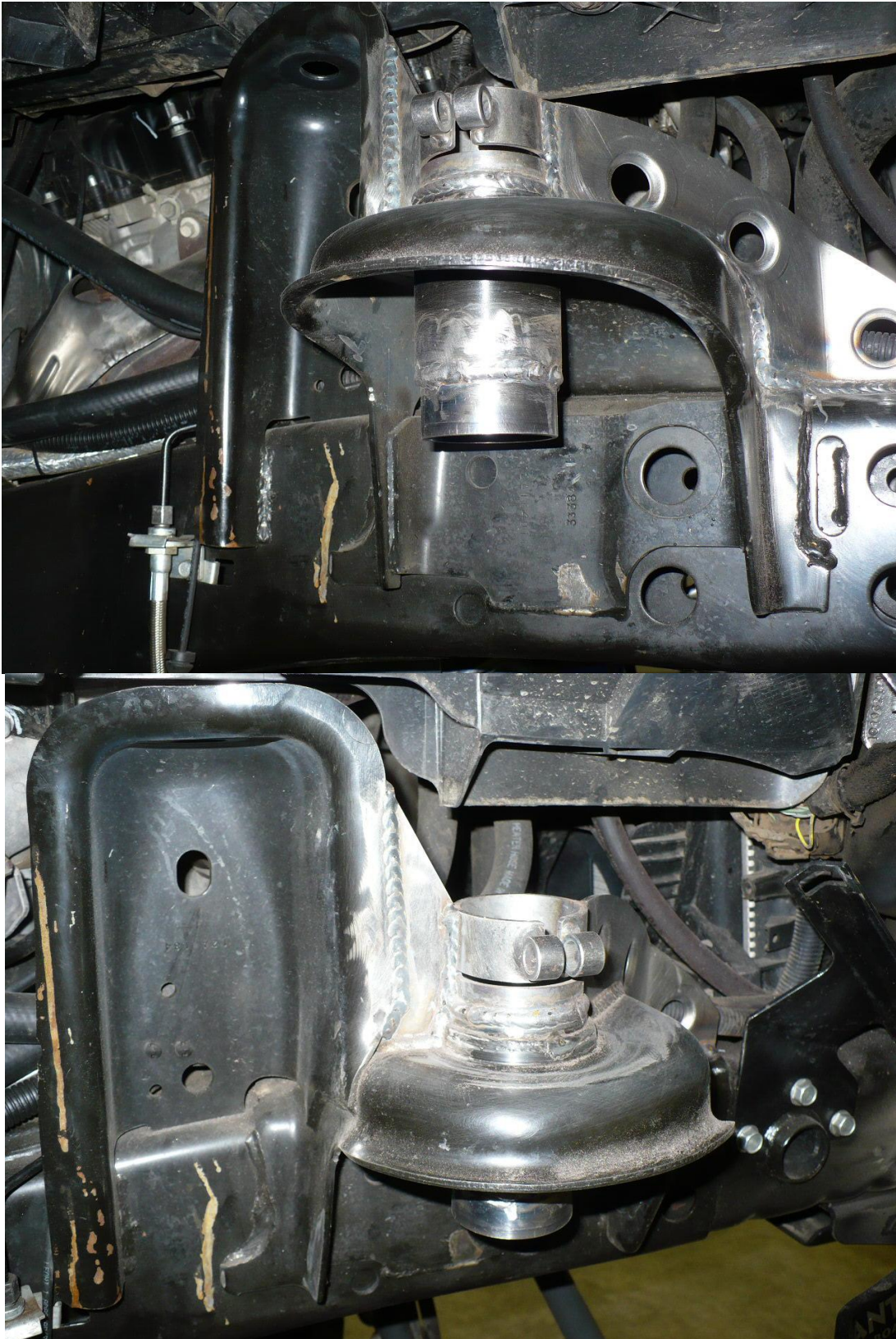

20) Once welded, paint all exposed areas of metal to prevent corrosion.

21) Install air bumps with a light coating of anti-seize. We recommend running between 80 and 100 psi on front air bumps.

22) Reassemble suspension and components removed during installation.

Installation is Complete